



6949

6949

# SUPER-POWER SHIELDED-GRID BEAM TRIODE

COAXIAL-ELECTRODE STRUCTURE      WATER-COOLED ELECTRODES  
500-KW CW POWER OUTPUT            INTEGRAL WATER DUCTS

*Useful with full input up to 75 Mc*

## GENERAL DATA

### Electrical:

Filament, Multistrand Thoriated Tungsten:

Voltage (Single-phase AC or DC) . . . . .	{ 7.3 min. volts	
	{ 7.8 max. volts	
Current at 7.3 volts. . . . .	1040	amp
Current at 7.8 volts. . . . .	1130	amp
Starting current. . . . .	Must never exceed 1700 amperes, even momentarily	
Cold resistance . . . . .	0.0013	ohm
Minimum heating time. . . . .	60	seconds

Amplification Factor, for dc grid volts = -50 and dc plate voltage adjusted to give dc plate current of 10 amperes . . . . . 60

Direct Interelectrode Capacitances:

Grid to plate . . . . .	12	$\mu\mu\text{f}$
Grid to filament. . . . .	1300	$\mu\mu\text{f}$
Plate to filament . . . . .	160	$\mu\mu\text{f}$

### Mechanical:

Operating Position. . . . . Vertical, with lifting ring up

Maximum Overall Length. . . . . 40"

Maximum Diameter. . . . . 10.06"

Weight (Approx.). . . . . 140 lbs

Terminal Connections (See Dimensional Outline):

F<sub>C</sub> - Filament  
Cylindrical  
Terminal

F<sub>F</sub> - Filament  
Flange  
Terminal

K<sub>R1</sub> - Output-  
Circuit-  
Return  
Terminal

P - Plate  
Terminal

K<sub>R2</sub> - Flange  
Input-  
Circuit-  
Return  
Terminal

K<sub>R3</sub> - Cylindrical  
Input-  
Circuit-  
Return  
Terminal

G - Grid  
Terminal

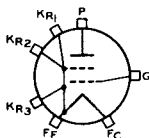

### Air Cooling:

It is important that the temperature of any external part of the tube should not exceed 150° C. In general, forced-air cooling of the ceramic bushings will not be required unless the 6949 is used in cavity-type circuits or in a confined space without free circulation of air. Under such conditions, provision should be made for blowing an adequate quantity of air at the ceramic bushings to limit their temperature to 150° C. Forced-air cooling of the output-



6949

## SUPER-POWER SHIELDED- GRID BEAM TRIODE

circuit-return terminal ( $K_{R1}$ ) and the flange input-circuit-return terminal ( $K_{R2}$ ) may be necessary to prevent exceeding the maximum temperature rating of  $150^{\circ}\text{C}$ , particularly at vhf frequencies.

### Water Cooling:

Water cooling of the beam-forming cylinder, grid-terminal, and the plate is required. The water flow must start before application of any voltages and preferably should continue for several minutes after removal of all voltages. Interlocking of the water flow for each of the cooled elements with all power supplies is recommended to prevent tube damage in case of failure of adequate water flow. The use of distilled water is essential.

### Water Flow:

	Absolute Min. Flow gpm	Typical Flow gpm	Pressure Drop* for Typical Flow psi	Max. Gauge Pres- sure <sup>□</sup> psi
To plate (in direction shown on <i>Dimensional Outline</i> ):				
For plate dissipation up to 125 kw. . . . .	40	44	18	100
For plate dissipation of 260 kw . . . . .	60	66	35	100
For plate dissipation of 330 kw . . . . .	70	77	48	100
For plate dissipation of 400 kw . . . . .	80	88	65	100
To grid-terminal connector . . . . .	1	-	-	-
To beam-forming cylinder . . . . .	7	8	9	50
Outlet Water Temperature (Any outlet) . . . . .			70 max.	$^{\circ}\text{C}$
Minimum Plate-Water-Column Resistance . . . . .			1/2 megohm per kv of dc plate voltage	
Ceramic-Bushing Temperature . . . . .			150 max.	$^{\circ}\text{C}$
Metal-Surface Temperature . . . . .			150 max.	$^{\circ}\text{C}$

### Fittings:

Fittings for the plate and beam-forming-cylinder water connections may be obtained from the Breco Division, Perfecting Service Co., 332 Atando Ave., Charlotte 6, North Carolina, USA.

\*<sup>□</sup>: See next page.



6949

6949

## SUPER-POWER SHIELDED- GRID BEAM TRIODE

### LINEAR RF POWER AMPLIFIER Single-Sideband Suppressed-Carrier Service

*Crest of modulation conditions*

#### Maximum CCS<sup>®</sup> Ratings, Absolute Values:

*For altitudes up to 5,000 feet and frequencies up to 75 Mc*

DC PLATE VOLTAGE . . . . .	20000 max.	volts
MAX.-SIGNAL DC PLATE CURRENT . . . . .	60 max.	amp
MAX.-SIGNAL PLATE INPUT . . . . .	1100000 max.	watts
MAX.-SIGNAL DC GRID CURRENT . . . . .	1.5 max.	amp
PLATE DISSIPATION (Average) . . . . .	400000 max.	watts

#### Typical CCS Class B Operation at 10 Mc:

DC Plate Voltage . . . . .	18000	volts
DC Grid Voltage (Approx.)* . . . . .	-300	volts
Zero-Signal DC Plate Current . . . . .	5	amp
Effective RF Load Resistance . . . . .	170	ohms

#### "Single-Tone" Operation:<sup>⊕</sup>

Max.-signal dc plate current . . . . .	57	amp
Max.-signal dc grid current . . . . .	0.35	amp
Max.-signal peak rf grid voltage . . . . .	1900	volts
Max.-signal driving power (Approx.) . . . . .	10000**	watts
Max.-signal power output (Approx.) . . . . .	600000	watts

#### "Two-Tone" Operation:<sup>⊕⊕</sup>

Average dc plate current . . . . .	37	amp
Average dc grid current . . . . .	0.22	amp
Peak envelope rf grid voltage . . . . .	1900	volts
Average power output (Approx.) . . . . .	300000	watts
Peak envelope power output (Approx.) . . . . .	600000	watts

**RF POWER AMPLIFIER — Class C Telegraphy<sup>##</sup>**  
and

**RF POWER AMPLIFIER — Class C FM Telephony**

#### Maximum CCS<sup>®</sup> Ratings, Absolute Values:

*For altitudes up to 5,000 feet and frequencies up to 75 Mc*

DC PLATE VOLTAGE . . . . .	20000 max.	volts
DC GRID VOLTAGE . . . . .	-1000 max.	volts
DC PLATE CURRENT . . . . .	50 max.	amp
DC GRID CURRENT . . . . .	1.5 max.	amp
PLATE INPUT . . . . .	1000000 max.	watts
PLATE DISSIPATION . . . . .	400000 max.	watts

#### Typical CCS Operation at 425 Kc:

DC Plate Voltage . . . . .	17500	volts
DC Grid Voltage <sup>▲</sup> . . . . .	-625	volts
Peak RF Grid Voltage . . . . .	2000	volts
DC Plate Current . . . . .	40	amp
DC Grid Current . . . . .	1	amp

⊕, ⊕, ●, \*, ⊕, \*\*, ⊕⊕, ##, ▲: See next page.

6949



6949

## SUPER-POWER SHIELDED- GRID BEAM TRIODE

Driving Power (Approx.) <sup>↓</sup> . . . . .	2000	watts
Useful Power Output (Approx.) . . .	500000	watts

### CHARACTERISTICS RANGE VALUES FOR EQUIPMENT DESIGN

	Note	Min.	Max.	
Filament Current. . . . .	1	870	1100	amp
Amplification Factor. . . . .	1,2	48	74	
Direct Interelectrode Capacitances:				
Grid to plate . . . . .	-	-	20	μmf
Grid to filament. . . . .	-	1150	1550	μmf
Plate to filament . . . . .	-	140	170	μmf

Note 1: With 7.3 volts ac on filament.

Note 2: For dc grid volts = -50 and dc plate voltage adjusted to give dc plate current of 10 amperes.

⊕ Directly across cooled element for the indicated typical flow.

□ At tube inlets.

● Continuous Commercial Service.

\* Obtained from a fixed supply. Value should be adjusted to give indicated value of zero-signal plate current.

⊕ "Single-Tone" operation refers to that class of amplifier service in which the grid-No.1 input consists of a monofrequency rf signal having constant amplitude. This signal is produced in a single-sideband suppressed-carrier system when a single audio frequency of constant amplitude is applied to the input of the system.

\*\* Includes tube losses, circuit losses, and "swamping power" losses.

⊕⊕ "Two-Tone" operation refers to the simultaneous amplification of the two equal-amplitude, radio-frequency signals resulting from modulation of a single-sideband, suppressed-carrier transmitter by two audio-frequency signals of equal amplitude. The data shown for "Two-Tone" modulation refer to the case in which the peak amplitude of the resultant rf grid signal is equal to the "Max.-Signal Peak RF Grid-No.1 Voltage" as specified under "Single-Tone" modulation.

## Key-down conditions per tube without amplitude modulation. Modulation essentially negative may be used if the positive peak of the audio-frequency envelope does not exceed 115% of the carrier conditions.

▲ Obtained from fixed supply.

↓ Additional driving power is required at frequencies where circuit losses become significant.

### OPERATING CONSIDERATIONS

A high-speed, electronic protective device must be used to remove the plate voltage within a few microseconds in the event of abnormal operation such as internal arcing. The protective device employed to remove the plate voltage in any installation must be approved by the RCA Electron Tube Division. In addition, the grid circuit should be provided with overload relays which will act to remove within a period of 0.1 second all grid power in the event of excessive grid-current flow. Inquiries concerning a high-speed, electronic protective device for removal of plate voltage from the 6949 may be addressed to Commercial Engineering, Electron Tube Division, RCA, Harrison, N.J.



6949

6949

# SUPER-POWER SHIELDED-GRID BEAM TRIODE

The 6949 can be operated with maximum ratings at frequencies up to 75 Mc and with reduced ratings to higher frequencies. The capabilities of the 6949 for operation at higher frequencies and at higher powers have not yet been determined but requests for information on specific applications will be welcomed.

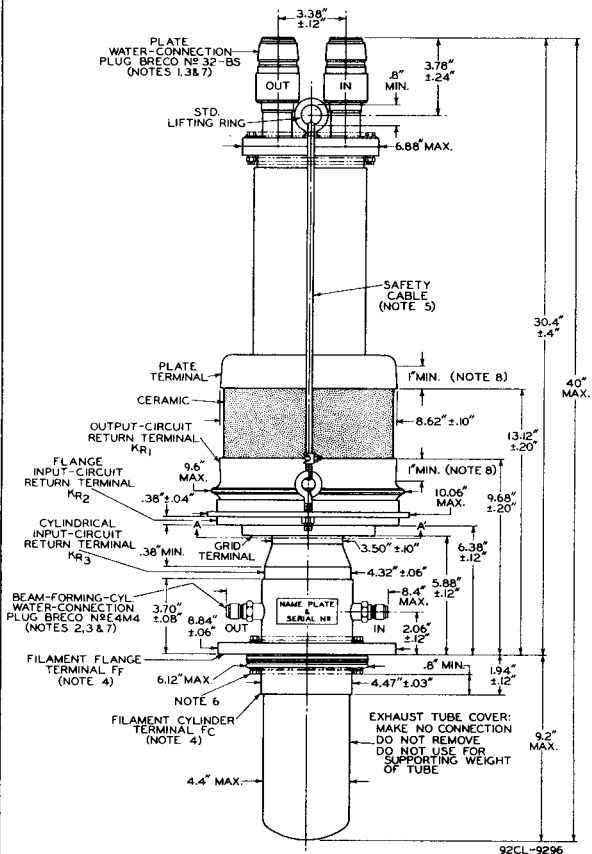

Notes 1 to 8: See next page.

6949



6949

# SUPER-POWER SHIELDED- GRID BEAM TRIODE

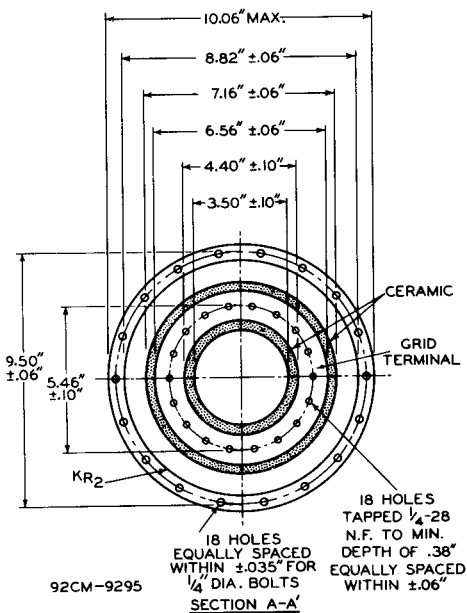

**NOTE 1:** SOCKET No.412-BS 1-1/2" FOR THIS PLUG MAY BE OBTAINED FROM BRECO DIVISION, PERFECTING SERVICE CO., 332 ATANDO AVE., CHARLOTTE 6, N.C.

**NOTE 2:** SOCKET No.4EF4 1/2" (WITH FEMALE PIPE-THREAD CONNECTION) OR SOCKET No.4EM4 1/2" (WITH MALE PIPE-THREAD CONNECTION) MAY BE OBTAINED FROM SUPPLIER INDICATED IN NOTE 1.

**NOTE 3:** DIRECTION OF WATER FLOW THROUGH TUBE MUST BE IN DIRECTION INDICATED BY MARKINGS AT WATER CONNECTIONS.

**NOTE 4:** USE FOR FILAMENT POWER ONLY. INPUT-CIRCUIT RETURN SHOULD BE MADE TO BOTH INPUT-CIRCUIT-RETURN TERMINALS ( $K_{R2}$  &  $K_{R3}$ ); OUTPUT-CIRCUIT RETURN SHOULD BE MADE TO OUTPUT-CIRCUIT-RETURN TERMINAL ( $K_{R1}$ ).

**NOTE 5:** REMOVE THIS CABLE BEFORE OPERATING TUBE AND KEEP CABLE FOR FUTURE TUBE HANDLING.

**NOTE 6:** DO NOT TAMPER WITH THESE BOLTS.

Notes 7 & 8: See next page.



6949

6949

## SUPER-POWER SHIELDED- GRID BEAM TRIODE

**NOTE 7:** INLET WATER CONNECTIONS (IN) ARE BOTH ON SAME SIDE OF TUBE AND TO THE RIGHT WHEN TUBE IS VIEWED WITH NAME PLATE TOWARD OBSERVER.

**NOTE 8:** THIS AREA IS SUBJECT TO A MAXIMUM TAPER OF 0.060" TO THE INCH. THE MAXIMUM DIAMETER ALONG THIS TAPER WILL BE ON THE END TOWARD THE CERAMIC.

### DETAILS OF SUGGESTED WATER-COOLED GRID-TERMINAL CONNECTOR

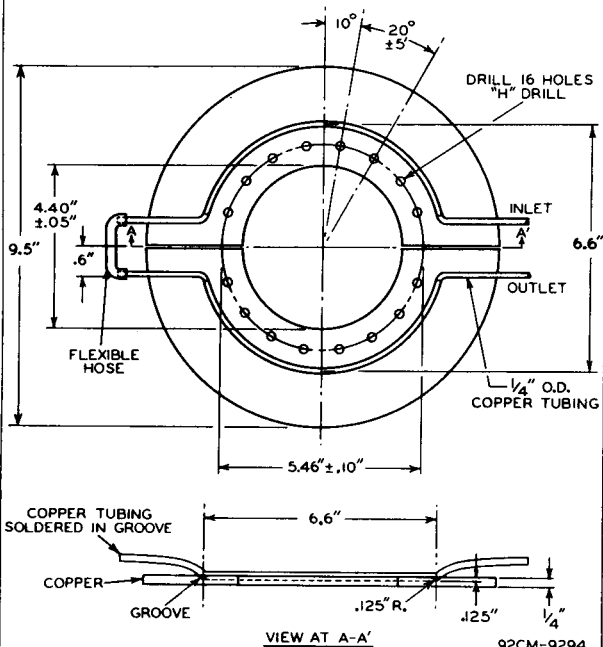



## TYPICAL CONSTANT-CURRENT CHARACTERISTICS

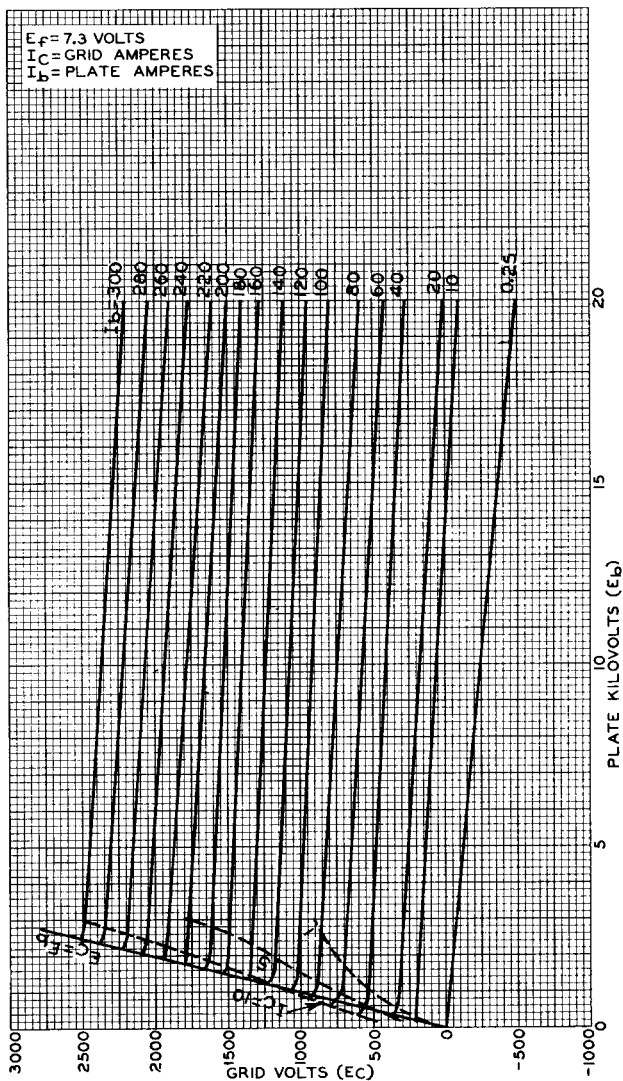

92CM-9305